

BLACKMER PARTS LIST

PUMP MODEL: X2.5B

961621 **PARTS LIST**
Page 1 of 2 **101-B06**

Section 101
Effective Feb 2014
Replaces Jan 2011

Keep with Instructions 101-B00 for Installation, Operation and Maintenance

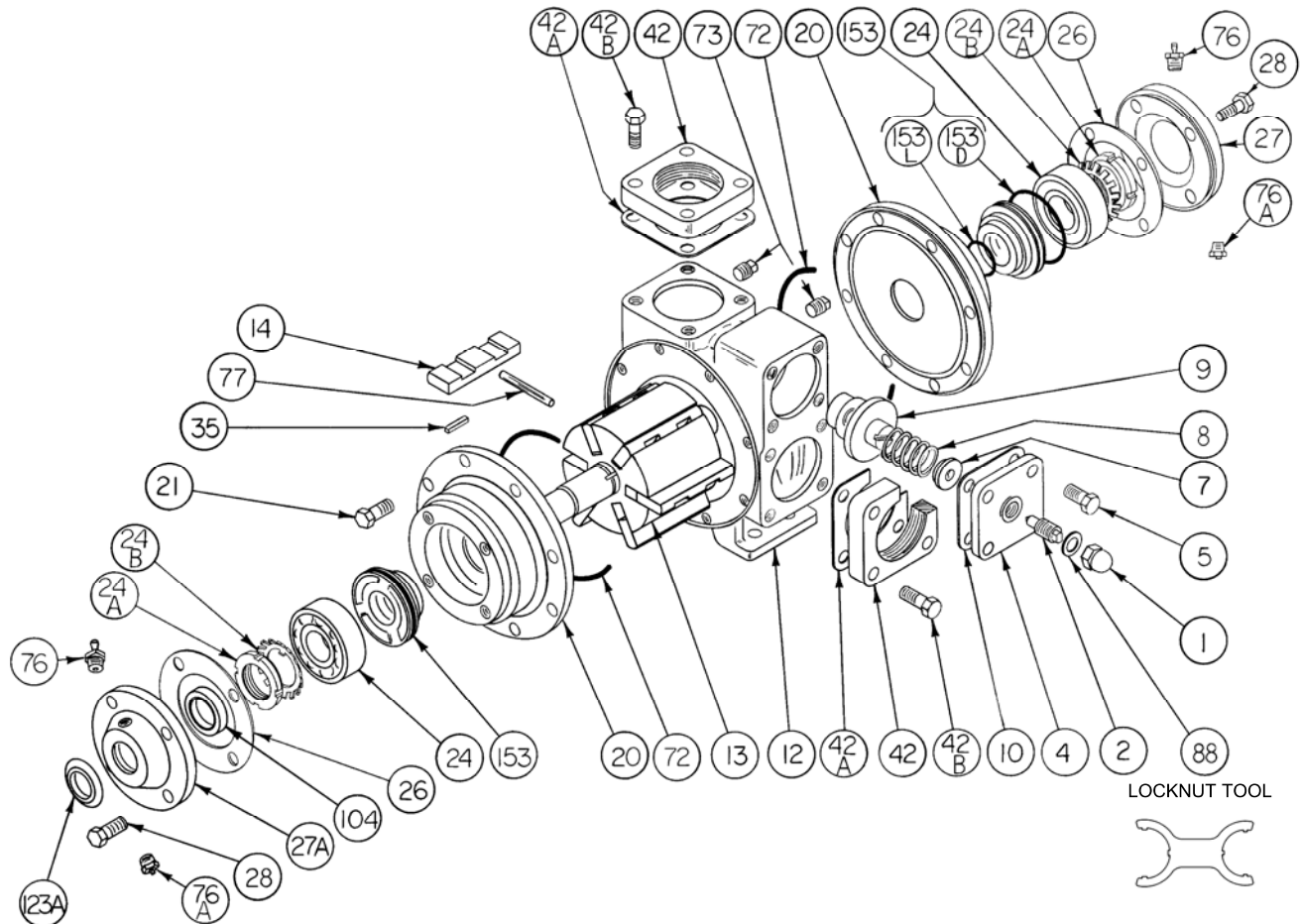

Ref. No.	Description	Parts per Pump	Part No.	Ref. No.	Description	Parts per Pump	Part No.
1	Cap - Relief Valve (R/V)	1	411453	24A	Locknut – Bearing	2	903521
2	Adjusting Screw - R/V	1	431401	24B	Lockwasher – Bearing	2	¹ 903522
4	Cover - R/V	1	411607	26	Gasket - Bearing Cover	2	¹ 383940
5	Capscrew - R/V Cover	4	920316	27	Bearing Cover – Outboard	1	041433
7	Spring Guide - R/V	1	423955	27A	Bearing Cover – Inboard	1	041431
8	Spring - R/V (41-50 psi)**	1	471608	28	Capscrews - Bearing Cover	8	920285
	Spring - R/V (51-110 psi)		471631	35	Key – Shaft, Square	1	^{1,2} 909209
	Spring - R/V (111-125 psi)		471614	42	Flange - 2 ½" NPT (Std.)*	2	651611
9	Valve, R/V (41-50 psi)**	1	451609	42A	Gasket - NPT Flange (Std.)	2	¹ 381650
	Valve, R/V (51-125 psi) (Std.)		451623	42B	Capscrews - NPT Flange (Std.)	8	920532
	Valve, R/V (51-125 psi) (Nickel Plated)		451624	72	O-Ring - Head (FKM) (Std.)	2	¹ 701914
					O-Ring - Head (PTFE)		702242
10	Gasket - R/V Cover	1	¹ 531603		O-Ring - Head (Buna-N)		701947
12	Cylinder	1	021605	73	Gage Plug	2	908198
				76	Grease Fitting	2	317815
				76A	Grease Relief Fitting	2	701992
13	Rotor & Shaft Assembly	1	261667	77	Push Rod	3	¹ 121607
	EC Rotor & Shaft Assembly		261669	88	Gasket - R/V Cap	1	¹ 701981
	(Both R/S Include Ref. No. 24A & 24B)			104	Grease Seal	1	¹ 331918
14	Vane - Duravane (Std.)	6	¹ 091619	123A	Dirt Shield	1	¹ 701480
	Vane - EC Cast Iron		091621		Tool - Locknut		903091
	Vane - EC Laminate		091627		Kit - Maintenance		898957
20	Head	2	031425				
21	Capscrews - Head	16	920331				
24	Ball Bearing	2	¹ 903156				

¹ Included in Maintenance Kit ² Maintenance Kit also includes Woodruff Key 909130 used previously
* See Page 2 for Weld / ANSI flange options. SS = Stainless Steel. EC = Extra-Clearance.
** R/V Spring p/n 471608 and Valve p/n 451609 MUST be used together to achieve listed pressures.

MECHANICAL SEALS

Ref. No.	Part Name	Parts Per Pump	Part No.
153	Mechanical Seal Complete - (Std.) Cast Iron Stationary Seat, Carbon Seal Face, FKM O-Rings. (ICV)	2	¹ 331655
	Mechanical Seal Complete - Cast Iron Stationary Seat, PTFE O-Ring, Carbon Seal Face w/ PTFE Seal Ring. (IAC)		331673
	Mechanical Seal Complete - Stainless Steel Stationary Seat, PTFE O-Ring, Carbon Seal Face w/ PTFE Seal Ring. (WAC)		331648
	Mechanical Seal Complete - Cast Iron Stationary Seat, Carbon Seal Face, Buna-N O-Rings. (INC)		331601
153D	O-Ring - Stationary (FKM)	2	701921
	O-Ring - Stationary (PTFE)		702056
	O-Ring - Stationary (Buna-N)		701934
153L	O-Ring - Rotating (FKM)	2	701980
	Seal Ring - Rotating (PTFE)		**
	O-Ring - Rotating (Buna-N)		701922

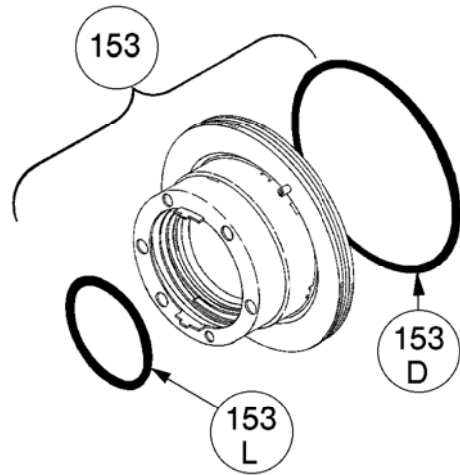

¹ Included in Maintenance Kit

** PTFE Rotating Seal Ring is not available as a separate part.

FLANGE OPTIONS

Ref. No.	Part Name	Parts Per Pump	Part No.
42	Flange - 2 1/2" Weld	2	651610
	Flange - 3" ANSI		651617
42B	Capscrews - Weld / ANSI Flange	8	920491
42C	O-Ring - Weld/ANSI Flange (FKM)	2	701924
	O-Ring - Weld/ANSI Flange (PTFE)		702079
	O-Ring - Weld/ANSI Flange (Buna-N)		701925

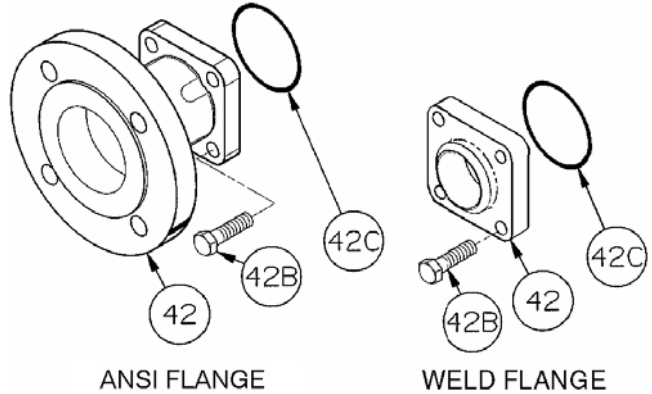

ANSI FLANGE

WELD FLANGE

