

OPERATOR'S MANUAL PX01X-XXX-XXX-AXXX

INCLUDING: OPERATION, INSTALLATION & MAINTENANCE

RELEASED: 3-7-13

REVISED: 4-25-14

(REV. F)

1/4" DIAPHRAGM PUMP 1:1 RATIO (NON-METALLIC)



**READ THIS MANUAL CAREFULLY BEFORE INSTALLING,
OPERATING OR SERVICING THIS EQUIPMENT.**

It is the responsibility of the employer to place this information in the hands of the operator. Keep for future reference.

PUMP DATA

Models see Model Description Chart on page 2 for
"-XXX" options

Pump Type . . Non-Metallic Air Operated Double Diaphragm

Material see Model Description Chart

Weight Polypropylene 2.86 lbs (1.30 kgs)
PVDF 3.88 lbs (1.76 kgs)
Acetal 3.52 lbs (1.60 kgs)

Maximum Air Inlet Pressure 125 psig (8.6 bar)

Minimum Air Inlet Pressure 10 psig (0.69 bar)

Maximum Outlet Pressure 125 psig (8.6 bar)

Maximum Flow Rate 5.3 gpm (20 lpm)

Maximum Material Inlet Pressure . . . 10 psig (0.69 bar)

Displacement / Cycle @ 125 p.s.i.g .. 0.019 gal / 0.072 ltrs

Maximum Particle Size 1/16" dia.(1.6 mm)

**Maximum Temperature Limits (diaphragm / ball / seat
material)**

Acetal 10° to 180° F (-12° to 82° C)
E.P.R. / EPDM -60° to 280° F (-51° to 138° C)
Kynar® PVDF 10° to 200° F (-12° to 93° C)
Hytrel® -20° to 150° F (-29° to 66° C)
Neoprene 0° to 200° F (-18° to 93° C)
Nitrile® 10° to 180° F (-12° to 82° C)
Polypropylene 35° to 175° F (2° to 79° C)
Viton® -40° to 350° F (-40° to 177° C)
Santoprene® -40° to 225° F (-40° to 107° C)
PTFE 40° to 225° F (4° to 107° C)

Dimensional Data see page 10

Noise Level @ 70 p.s.i., 60 c.p.m. 62.3 db(A)①

① The pump sound pressure levels published here have been updated to an Equivalent Continuous Sound Level (L_{Aeq}) to meet the intent of ANSI S1.13-2005, CAGI-PNEUROP S5.1.

Mounting Adapter Plate Optional Accessory Kit (24123879) available.
Please contact your nearest **ARO / Ingersoll Rand** customer service or distributor for details.

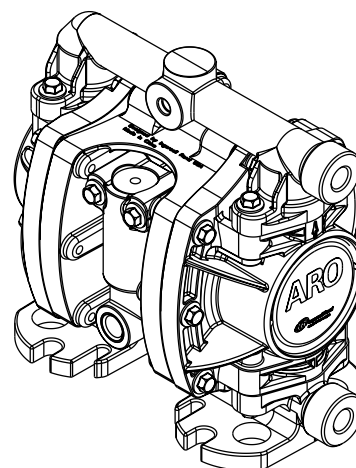

Model PD01X

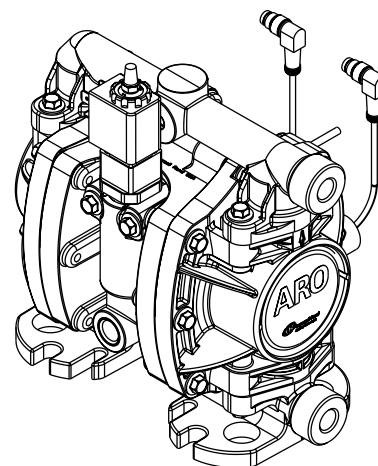

Model PE01X

Figure 1

INGERSOLL RAND COMPANY LTD

209 NORTH MAIN STREET – BRYAN, OHIO 43506

① (800) 495-0276 • FAX (800) 892-6276

© 2014

CCN 80448053

www.ingersollrandproducts.com

ARO  **Ingersoll Rand.**

MODEL DESCRIPTION CHART

Model Code Explanation

Example:	PX01	X	-	X	X	X	-	X	X	X	-	A	X	X	X
Model Series															
PD01- Standard Pump															
PE01- Electronic Interface															
Center Body Material															
E- Groundable Polypropylene															
F- Polypropylene with Leak Failure Detection															
P- Polypropylene															
Connection															
H- Hybrid 1/4" NPT / BSP															
Fluid Caps / Manifold Material															
D- Groundable Acetal															
E- Groundable Acetal (Multiple port)															
K- Kynar PVDF															
L- Kynar PVDF (Multiple port)															
P- Polypropylene															
R- Polypropylene (Multiple port)															
Hardware Material															
S- Stainless Steel															
Seat / Spacer Material															
D- Acetal															
K- Kynar PVDF															
P- Polypropylene															
0- Polypropylene (Flex Check Spacer)															
1- Acetal (Flex Check Spacer)															
2- PVDF (Flex Check Spacer)															
Check Material															
A- Santropene															
C- Hytrel															
G- Nitrile															
J- Nitrile (flex check only)															
K- EPR (flex check only)															
L- Viton (flex check only)															
N- Neoprene (flex check only)															
T- PTFE															
Diaphragm / O-Ring Material															
A- Santoprene															
C- Hytrel															
G- Nitrile															
T- PTFE															
Revision															
A- Revision															
Specialty Code 1 (Blank if no Speciality Code)															
A- Solenoid 120VAC,110VAC AND 60VDC															
B- Solenoid 12VDC, 24VAC and 22VAC															
C- Solenoid 240VAC, 220VAC AND 120VDC															
D- Solenoid 24VDC, 48VAC and 44VAC															
G- Solenoid 12VDC ATEX Zone 1															
H- Solenoid 24VDC ATEX Zone 1															
K- Solenoid 220VAC ATEX Zone 1															
N- Solenoid with no Coil															
0- Standard Valve Block (No Solenoid)															
Specialty Code 2 (Blank if no Speciality Code)															
E- End of stroke feedback / cycle sensing (with M12 Circular Connector) + Leak Detection															
F- End of stroke feedback / cycle sensing (with M12 Circular Connector)															
L- Leak Detection															
N- End of stroke feedback / cycle sensing (no Connector) + Leak Detection															
P- End of stroke feedback (No Connector)															
0- No option															
Special Testing															

For Special Testing options, please contact your nearest **Ingersoll Rand** Customer Service Representative or Distributor.

NOTICE: All possible options are shown in the chart, however, certain combinations may not be recommended. Consult a representative or the factory if you have questions concerning availability.

OPERATING AND SAFETY PRECAUTIONS

READ, UNDERSTAND, AND FOLLOW THIS INFORMATION TO AVOID INJURY AND PROPERTY DAMAGE.



⚠ WARNING **EXCESSIVE AIR PRESSURE.** Can cause personal injury, pump damage or property damage.

- Do not exceed the maximum inlet air pressure as stated on the pump model plate.
- Be sure material hoses and other components are able to withstand fluid pressures developed by this pump. Check all hoses for damage or wear. Be certain dispensing device is clean and in proper working condition.

⚠ WARNING **STATIC SPARK.** Can cause explosion resulting in severe injury or death. Ground pump and pumping system.

- PX01X-HDS-XXX are Groundable Acetal pumps: Use the pump ground lug provided. Connect to a 12 ga. (minimum) wire (kit 66885-1 is included) to a good earth ground source.
- Sparks can ignite flammable material and vapors.
- The pumping system and object being sprayed must be grounded when it is pumping, flushing, recirculating or spraying flammable materials such as paints, solvents, lacquers, etc. or used in a location where surrounding atmosphere is conducive to spontaneous combustion. Ground the dispensing valve or device, containers, hoses and any object to which material is being pumped.
- Secure pump, connections and all contact points to avoid vibration and generation of contact or static spark.
- Consult local building codes and electrical codes for specific grounding requirements.
- After grounding, periodically verify continuity of electrical path to ground. Test with an ohmmeter from each component (e.g., hoses, pump, clamps, container, spray gun, etc.) to ground to insure continuity. Ohmmeter should show 0.1 ohms or less.
- Submerge the outlet hose end, dispensing valve or device in the material being dispensed if possible. (Avoid free streaming of material being dispensed.)
- Use hoses incorporating a static wire.
- Use proper ventilation.
- Keep inflammables away from heat, open flames and sparks.
- Keep containers closed when not in use.

⚠ WARNING **Pump exhaust may contain contaminants.** Can cause severe injury. Pipe exhaust away from work area and personnel.

- In the event of a diaphragm rupture, material can be forced out of the air exhaust muffler.
- Pipe the exhaust to a safe remote location when pumping hazardous or inflammable materials.
- Use a grounded 1/4" minimum i.d. hose between the pump and the muffler.

⚠ WARNING **HAZARDOUS PRESSURE.** Can result in serious injury or property damage. Do not service or clean pump, hoses or dispensing valve while the system is pressurized.

- Disconnect air supply line and relieve pressure from the system by opening dispensing valve or device and / or carefully and slowly loosening and removing outlet hose or piping from pump.

⚠ WARNING **HAZARDOUS MATERIALS.** Can cause serious injury or property damage. Do not attempt to return a pump to the factory or service center that contains hazardous material. Safe handling practices must comply with local and national laws and safety code requirements.

- Obtain Material Safety Data Sheets on all materials from the supplier for proper handling instructions.

⚠ CAUTION Verify the chemical compatibility of the pump wetted parts and the substance being pumped, flushed or recirculated. Chemical compatibility may change with temperature and concentration of the chemical(s) within the substances being pumped, flushed or circulated. For specific fluid compatibility, consult the chemical manufacturer.

⚠ CAUTION Maximum temperatures are based on mechanical stress only. Certain chemicals will significantly reduce maximum safe operating temperature. Consult the chemical manufacturer for chemical compatibility and temperature limits. Refer to PUMP DATA on page 1 of this manual.

⚠ CAUTION Be certain all operators of this equipment have been trained for safe working practices, understand it's limitations, and wear safety goggles / equipment when required.

⚠ CAUTION Do not use the pump for the structural support of the piping system. Be certain the system components are properly supported to prevent stress on the pump parts.

- Suction and discharge connections should be flexible connections (such as hose), not rigid piped, and should be compatible with the substance being pumped.

⚠ CAUTION Prevent unnecessary damage to the pump. Do not allow pump to operate when out of material for long periods of time.

- Disconnect air line from pump when system sits idle for long periods of time.

⚠ CAUTION Use only genuine ARO® replacement parts to assure compatible pressure rating and longest service life.

NOTICE Install the pump in the vertical position. The pump may not prime properly if the balls do not check by gravity upon start-up.

NOTICE **RE-TORQUE ALL FASTENERS BEFORE OPERATION.** Creep of housing and gasket materials may cause fasteners to loosen. Re-torque all fasteners to insure against fluid or air leakage.

NOTICE Replacement warning labels are available upon request: Static Spark" pn \ 93616-1, Diaphragm Rupture" pn \ 93122.

⚠ WARNING = Hazards or unsafe practices which could result in severe personal injury, death or substantial property damage.

⚠ CAUTION = Hazards or unsafe practices which could result in minor personal injury, product or property damage.

NOTICE = Important installation, operation or maintenance information.

GENERAL DESCRIPTION

The ARO diaphragm pump offers high volume delivery even at low air pressures, easy self priming and the ability to pump various viscosity materials. The pump is designed to correspond to the needs of the user by offering a variety of wetted parts configurations to handle almost any application.

Air operated double diaphragm pumps utilize a pressure differential in the air chambers to alternately create suction and positive fluid pressure in the fluid chambers. Flat checks insure a positive flow of fluid.

Pump cycling will begin as air pressure is applied and it will continue to pump and keep up with the demand. It will build and maintain line pressure and will stop cycling once maximum line pressure is reached (dispensing device closed) and will resume pumping as needed.

The Acetal material used in this pump contains stainless steel fibers. It's conductivity allows it to be connected to a suitable ground. A ground screw is provided for this.

AIR AND LUBE REQUIREMENTS

⚠ WARNING EXCESSIVE AIR PRESSURE. Can cause pump damage, personal injury or property damage.

- A filter capable of filtering out particles larger than 50 microns should be used on the air supply. In most applications there is no lubrication required other than the "O" ring lubricant which is applied during assembly or repair.
- The pump, when fitted with flex checks, can be rotated 360° to suit the application. It may be mounted upside down or on the wall with no effect on suction lift or operating efficiency. The filter and regulator need to be oriented in a normal vertical direction to function properly.
- If lubricated air is present, make sure that it is compatible with the "O" rings and seals in the air motor section of the pump.

INSTALLATION

- Apply PTFE tape or pipe sealant to threads upon assembly to prevent leakage.
- Secure the diaphragm pump legs to a suitable surface to insure against damage by vibration.
- When the diaphragm pump is used in a forced-feed (flooded inlet) situation, it is recommended that a "Check Valve" be installed at the air inlet.

OPERATING INSTRUCTIONS

- Always flush the pump with a solvent compatible with the material being pumped if the material being pumped is subject to "setting up" when not in use for a period of time.
- Disconnect the air supply from the pump if it is to be inactive for a few hours.
- The outlet material volume is governed not only by the air supply, but also by the material supply available at the inlet. The material supply tubing should not be too small or restrictive. Be sure not to use hose which might collapse.

MAINTENANCE

- This product is not intended to be repairable. However, some service items are available.
- Provide a clean work surface to protect sensitive internal moving parts from contamination from dirt and foreign matter during service disassembly and reassembly.
- Keep good records of service activity and include the pump in preventive maintenance program.
- At the end of its service life, please dispose of pump and contents properly.

PE01X PUMP OPERATION

- Solenoid control allows the cycle rate of the pump to be controlled electronically.
With Solenoid control, when the solenoid is energized, the pump strokes and dispenses the fluid in one chamber. When the solenoid is de-energized, the pump strokes in the opposite direction, dispensing the fluid in the other chamber.
By providing continuous ON - OFF signals to the solenoid, the fluid transfer rate may be increased or decreased remotely.
- End of stroke feedback can be used in conjunction with the solenoid valve to cycle the pump based upon completion of each stroke.
- The leak detection option incorporates an optical fluid sensor in each air chamber to provide a signal when a diaphragm has failed and fluid is leaking through the pump.

PARTS LIST / PX01X-XXX-XXX-AXXX

COMMON PARTS				
PX01X-XXX-XXX-AXXX				
Item	Description	[Mtl]	Qty	Part no
1	Rod Assembly (includes seals)	---	[1]	24028284
5	Washer, Diaphragm	[P]	[2]	23981541
77	Plate	---	[2]	93264
206	Caution Label	---	[1]	93122
207	Warning Label	---	[1]	93616-1
26	Screw	[SS]	[32]	23981574

MATERIAL CODE
[B] = Nitrile
[Co] = Copper
[D] = Acetal
[E] = E.P.R. / EPDM
[G] = Nitrile
[GP] = Groundable Polypropylene
[H] = Hytrel
[K] = Kynar PVDF
[N] = Neoprene
[P] = Polypropylene
[Sp] = Santoprene
[SS] = Stainless Steel
[T] = PTFE
[U] = Polyurethane
[V] = Viton

FLUID CONNECTION										
PX01X-XXX-XXX-AXXX										
		PX01X-HDS			PX01X-HKS			PX01X-HPS		
Item	Description	Part no	[Mtl]	Qty	Part no	[Mtl]	Qty	Part no	[Mtl]	Qty
6	Diaphragm Screw	93810-2	[D]	(2)	93810-3	[K]	(2)	93810-1	[P]	(2)
15	Fluid Cap	23981640	[D]	(2)	23981657	[K]	(2)	23981632	[P]	(2)
60	Inlet Manifold	23981681	[D]	(1)	23981699	[K]	(1)	23981673	[P]	(1)
61	Outlet Manifold	23981723	[D]	(1)	23981731	[K]	(1)	23981715	[P]	(1)
43	Ground Lug	93004	[Co]	(1)	---			---		

FLUID CONNECTION										
PX01X-XXX-XXX-AXXX										
		PX01X-HES			PX01X-HLS			PX01X-HRS		
Item	Description	Part no	[Mtl]	Qty	Part no	[Mtl]	Qty	Part no	[Mtl]	Qty
6	Diaphragm Screw	93810-2	[D]	(2)	93810-3	[K]	(2)	93810-1	[P]	(2)
15	Fluid Cap	23981640	[D]	(2)	23981657	[K]	(2)	23981632	[P]	(2)
60	Inlet Manifold	47516487001	[D]	(1)	47516488001	[K]	(1)	47516486001	[P]	(1)
61	Outlet Manifold	47516490001	[D]	(1)	47516491001	[K]	(1)	47516489001	[P]	(1)
43	Ground Lug	93004	[Co]	(1)	---			---		
63	Pipe Plug	93832-2	[D]	(4)	93832-3	[K]	(4)	93832-1	[P]	(4)

SEAT OPTIONS PX01X-XXX-XXX-AXXX				BALL / FLEX CHECK OPTIONS PX01X-XXX-XXX-AXXX							
"21"				"22" (5/8" o.d)				"42"			
-XXX	Seat	Qty	[Mtl]	-XXX	Ball	Qty	[Mtl]	-XXX	FLEX CHECK	Qty	[Mtl]
-DXX	96580-2	(4)	[D]	-XAX	96481-A	(4)	[Sp]	-XJX	96744-2	(4)	[B]
-KXX	96580-3	(4)	[K]	-XCX	96481-C	(4)	[H]	-XNX	96744-3	(4)	[N]
-PXX	96580-1	(4)	[P]	-XGX	96481-G	(4)	[B]	-XLX	96744-4	(4)	[V]
-HPS-0XX	96745	(4)	[P]	-XTX	96481-4	(4)	[T]	-XKX	96744-1	(4)	[E]
-HKS-2XX	96745-1	(4)	[K]								
-HDS-1XX	96745-2	(4)	[D]								

DIAPHRAGM OPTIONS PX01X-XXX-XXX-AXXX										
		"7"			"19"			"64"		
-XXX	Diaphragm	Qty	Mtl	Seal	Qty	Mtl	"O" Ring	Qty	Mtl	
-XXA	93808	(2)	[Sp]	93761	(4)	[E]	-----	---	---	
-XXC	93808-C	(2)	[H]	Y325-119	(4)	[B]	-----	---	---	
-XXG	93808-G	(2)	[B]	Y325-119	(4)	[B]	-----	---	---	
-XXT	93898	(2)	[T]	96514	(4)	[T]	93947	---	[B]	

Note: Item (19) O-ring is not used with Flex Check Options.

PARTS LIST / PX01X-XXX-XXX-AXXX

AIR SECTION PARTS

Item	Description	Part no	Qty	[Mtl]	Item	Description	Part no	Qty	[Mtl]
101	Center Body				403	Valve (All PE01X with Solenoid)	114102	(1)	
	(PD01X)	23981392	(1)	[P]	413	Coil Nut (All PE01X with Solenoid)	119380	(1)	
	(All PE01X without Diaphragm Failure Detection)	23981392	(1)	[P]	414	Coil ,120 VAC (PE01X-XXX-XXX-XAXXX)	116218-33	(1)	
	(PE01X With Diaphragm Failure Detection)	23981608	(1)	[P]		Coil ,24 VAC , 12VDC (PE01X-XXX-XXX-XBXXX)	116218-38	(1)	
	(PD01E and PE01E) (not available with Diaphragm Failure Detection)	24243354	(1)	[GP]		Coil ,240 VAC (PE01X-XXX-XXX-XCXXX)	116218-35	(1)	
107	Valve Block Plug					Coil ,48 VAC, 24VDC (PE01X-XXX-XXX-XDXXX)	116218-39	(1)	
	(PD01X, PE01X-XXX-XXX-X0XXX)	23981434	(1)	[P]		Coil, ATEX, 12VDC (PE01X-XXX-XXX-XGXXX)	117345-38	(1)	
	(All PE01X with Solenoid)	23981848	(1)	[P]		Coil, ATEX, 24VDC (PE01X-XXX-XXX-XHXXX)	117345-39	(1)	
111	Major Valve Spool Asm (includes seals)					Coil, ATEX, 220VAC (PE01X-XXX-XXX-XKXXX)	117345-35	(1)	
	(PD01X, PE01X-XXX-XXX-X0XXX)	24028268	(1)	[D]	415	O-Ring (All PE01X with Solenoid)	114103	(1)	[B]
	(All PE01X with Solenoid)	24086779	(1)	[D]	416	O-Ring (All PE01X with Solenoid)	114104	(1)	[B]
129	Muffler Baffle				417	Screw (All PE01X with Solenoid)	96728647	(2)	
	(PD01X, PE01X-XXX-XXX-X0XXX)	23981475	(1)	[P]	418	Tube (All PE01X with Solenoid)	15309974	(1)	[SS]
	(PE01X-XXX-XXX-XXNXX)	24110926	(1)	[P]	419	Seal (All PE01X with Solenoid)	96957	(1)	[B]
	(PE01X-XXX-XXX-XXPXX)	24110926	(1)	[P]	420	Snap Ring (All PE01X with Solenoid)	Y147-43	(1)	
	(PE01X-XXX-XXX-XXEXX)	24110934	(1)	[P]	421	Retainer (All PE01X with Solenoid)	15309990	(1)	[B]
	(PE01X-XXX-XXX-XXFXX)	24110934	(1)	[P]	429	Solenoid Muffler (All PE01X with Solenoid)	116464	(1)	
	(PE01X-XXX-XXX-XXLXX)	23981475	(1)	[P]					
132	Gasket	23981525	(1)	[B]					
135	Valve Block Assembly								
	(PD01X, PE01X-XXX-XXX-X0XXX)	24243388	(1)	[P]					
	(All PE01X with Solenoid)	24340275	(1)	[P]					
137	O-Ring (0.070 CS x 0.676 ID)	Y-325-17	(1)	[B]					
167	Pilot Valve Spool Assembly (includes seals)	24028276	(1)	[D]					
173	O-Ring	24243313	(1)	[U]					
283	Diaphragm Failure Detector								
	(PE01X-XXX-XXX-XXEXX)	96270-1	(2)						
	(PE01X-XXX-XXX-XXLXX)	96270-1	(2)						
	(PE01X-XXX-XXX-XXNXX)	96270-1	(2)						

PX01X-XXX-XXX-AXXX / AIR SECTION

PD01X-XXX-XXX-AXXX - Air Section

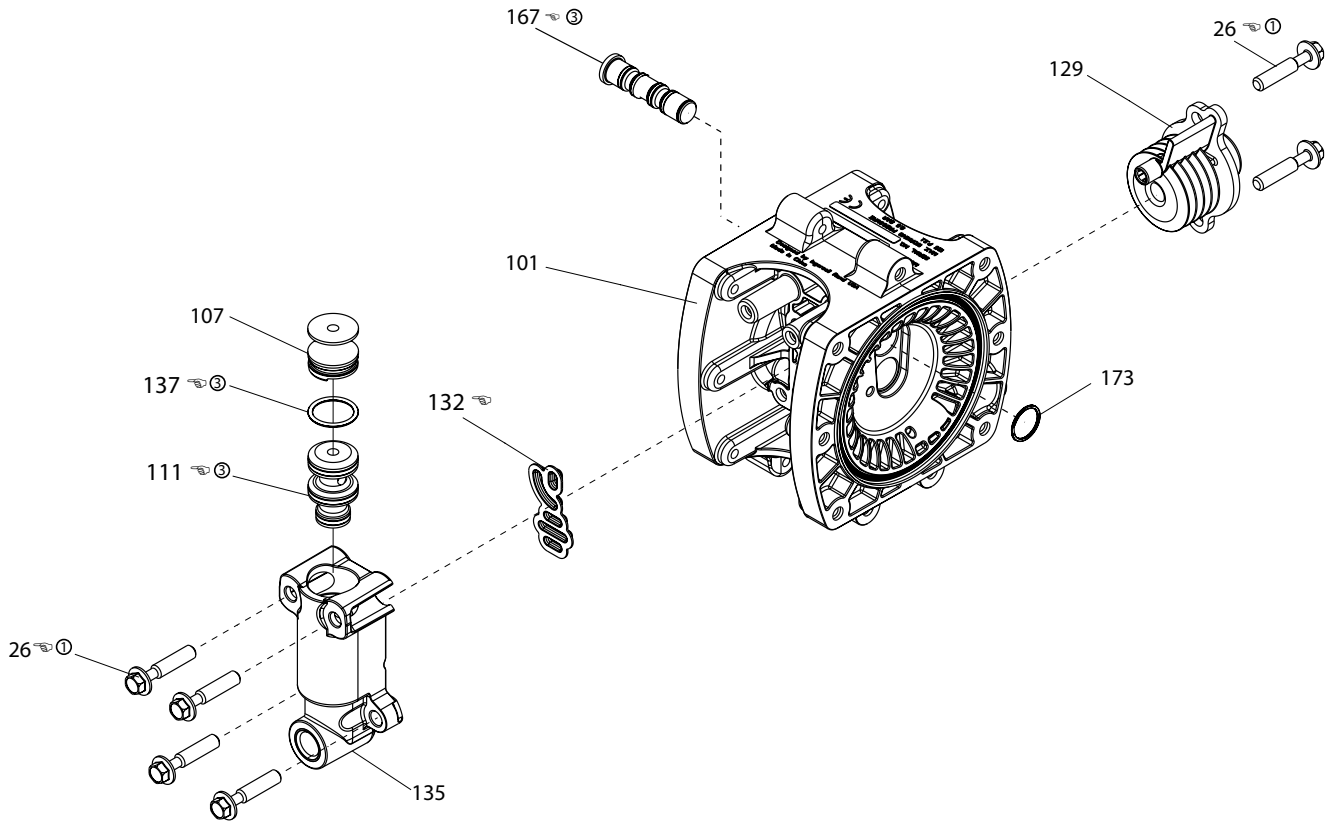

PE01X-XXX-XXX-AXXX- Air Section

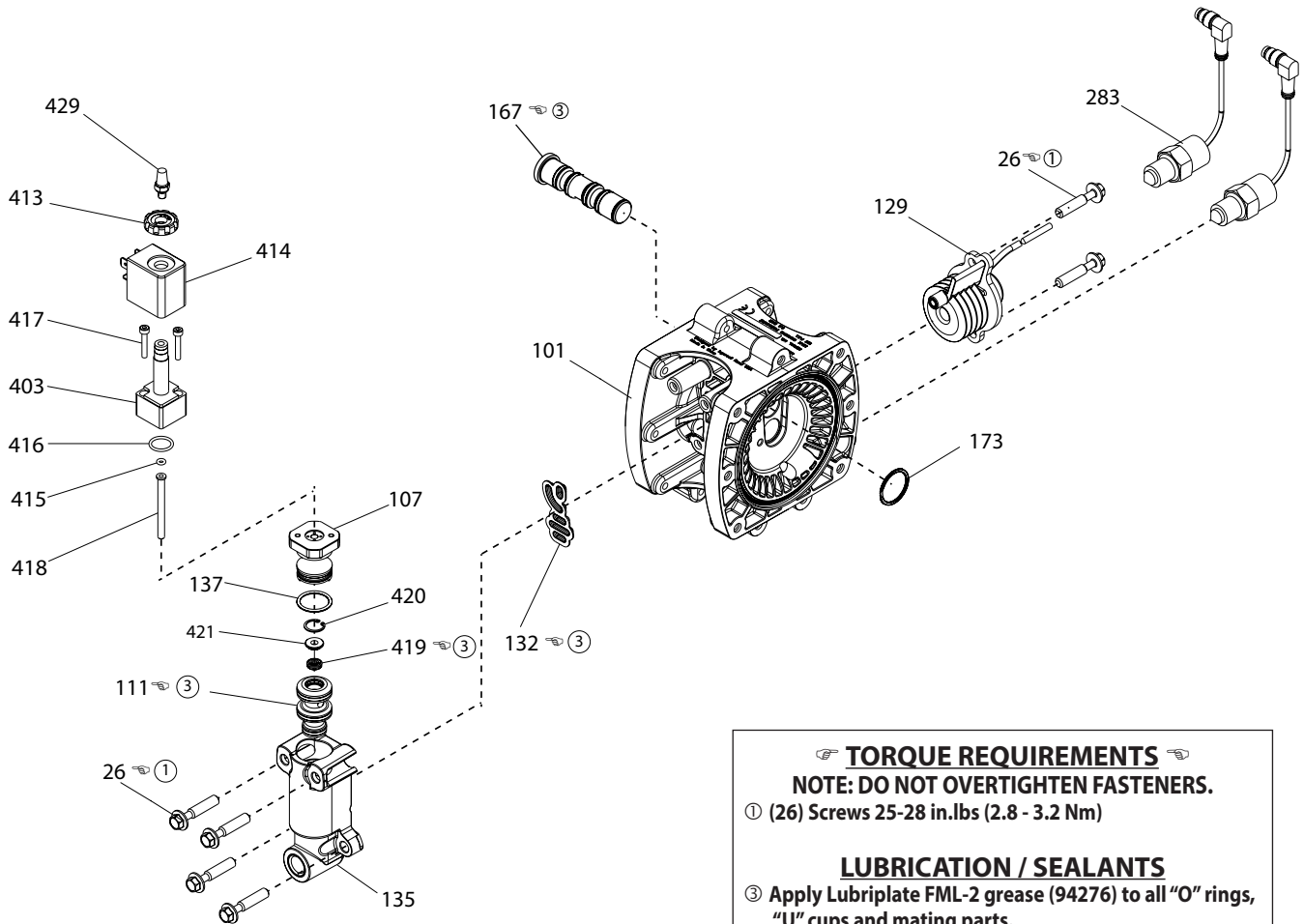

TORQUE REQUIREMENTS
 NOTE: DO NOT OVERTIGHTEN FASTENERS.
 ① (26) Screws 25-28 in.lbs (2.8 - 3.2 Nm)

LUBRICATION / SEALANTS
 ③ Apply Lubriplate FML-2 grease (94276) to all "O" rings, "U" cups and mating parts.
 ④ Apply Loctite® 242® to threads.

PE01X OPTION WIRING DIAGRAMS

End of Stroke / Cycle Sensor Pinout, M12 Connector

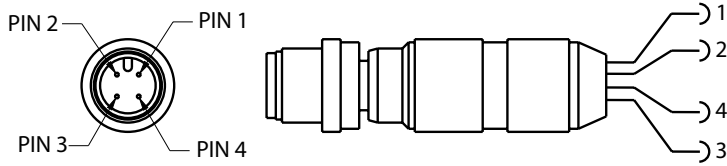

CABLE ASSEMBLY WIRING COLORS:

- PIN 1 - BROWN, POSITIVE VOLTAGE (+10 TO +30 VDC)
- PIN 2 - WHITE, NOT USED
- PIN 3 - BLUE, ZERO VOLTS
- PIN 4 - BLACK, SIGNAL

NOTE: WIRING COLORS ARE BASED ON AUTOMATION DIRECT CD12L AND CD12M 4-POLE CABLE ASSEMBLIES.

End of Stroke / Cycle Sensor Pinout Wiring Diagram (No Connector)

PNP Output

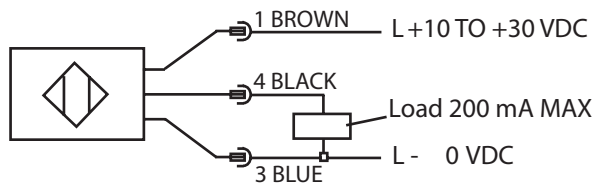

Diaphragm Failure Detector Wiring Diagram

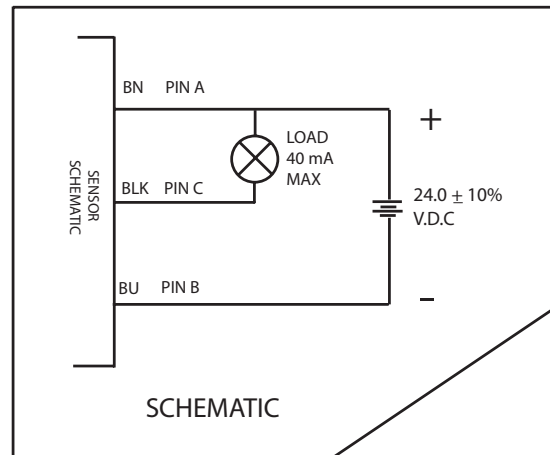
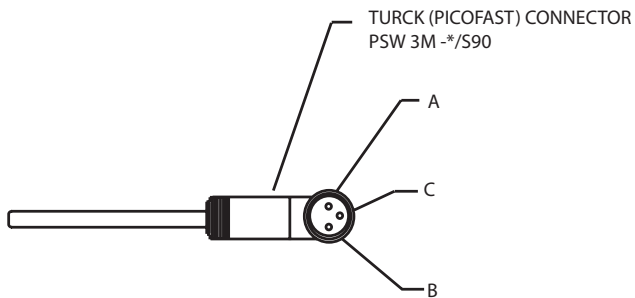

PINOUT	FUNCTION
A	+ 24 VDC
B	0 VDC
C	SIGNAL

DIMENSIONAL DATA

Dimensions shown are for reference only, they are displayed in inches and millimeters (mm).

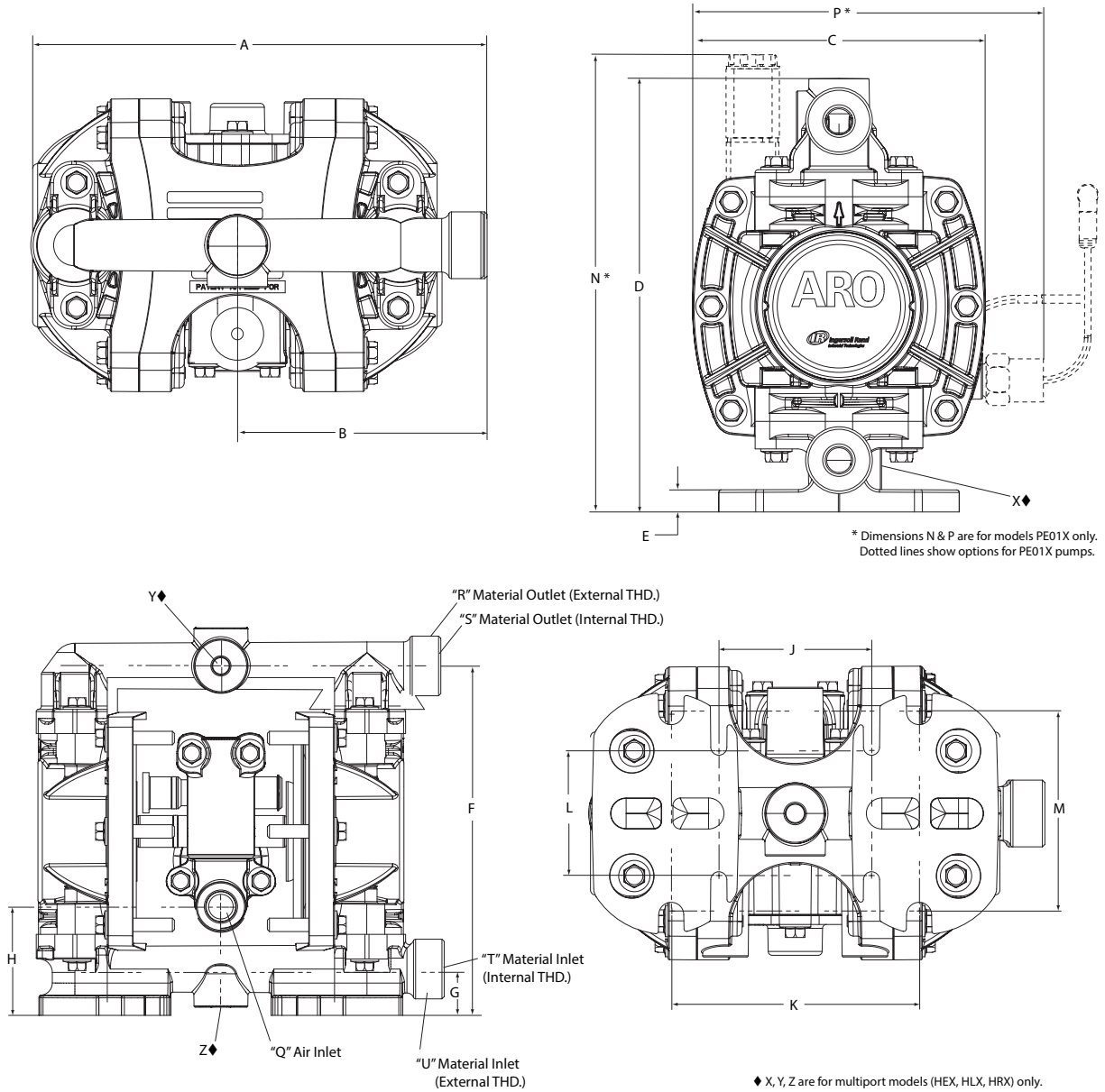

DIMENSIONS

A - 7.2" (182 mm)	H - 1.9" (48.6 mm)	Q - 1/4 - 18 PTF SAE Short	Z - 1/4 - 18 PTF SAE Short
B - 3.9" (100.0 mm)	J - 2.4" (61 mm)	R - 3/4-14 NPTF	
C - 4.6" (117.0 mm)	K - 3.9" (99 mm)	S - 1/4 NPTF / BSPT Hybrid ▲	
D - 6.8" (173.0 mm)	L - 2.1" (53 mm)	T - 1/4 NPTF / BSPT Hybrid ▲	
E - 0.3" (8.8 mm)	M - 3.2" (81 mm)	U - 3/4-14 NPTF	
F - 6.1" (156 mm)	N - 7.2" (184 mm)	X - 1/4-18 NPTF / BSPT Hybrid	
G - 0.8" (20.7 mm)	P - 5.6" (142.2 mm)	Y - 1/4 NPTF / BSPT Hybrid	

▲ Multiport Options Discharge Manifold has (2) and Inlet Manifold has (3).

